

MUTOH

ECO-SOLVENT PRINTER

Powered by
VerteLith
 GENUINE RIP SOFTWARE

AccuFINE

MS41
 Eco-Solvent
 Inks

CMYKx2 | CMYKLCmLkOr



XpertJet



1682SR Pro DUAL-PRINTHEAD

BUILT FOR PROFESSIONALS

The **MUTOH XpertJet 1682SR Pro** 64-inch Eco-Solvent Printer is equipped with staggered dual AccuFine HD printheads that provide ultra-fast print speeds. It's capable of producing smooth gradations while delivering high-quality printing, even with reduced resolutions, thanks to the optional 8-color (CMYKLCmLkOr) ink configuration.

Built for Professionals, the **XPJ-1682SR Pro** is packed with features such as Dropmaster 2 (automatic bi-directional alignments), Feed Master (automatic PF adjustment), Automatic Nozzle Checking Unit option with Nozzle Area Select (continuous printing), i-screen print effects (banding mitigation), and Media Tracker (roll remainder tracking), among other cutting-edge improvements brought on by the original XpertJet line.

The **XPJ-1682SR Pro** includes VerteLith™ Genuine RIP Software, bundled with FlexiDESIGNER MUTOH Edition 21 for the ultimate balance of speed and quality.



WRAPS



SIGNAGE



WALL COVERINGS



BANNERS

MUTOH

XpertJet 1682SR Pro

POWERED BY VERTELITH™ RIP SOFTWARE



MUTOH'S GENUINE RIP SOFTWARE BUNDLED WITH FLEXIDESIGNER MUTOH EDITION 21

NEW ACCUFINE HD PRINthead

IMPROVED DRYER SYSTEM



AUTOMATIC ALIGNMENTS

INTERNAL LED LIGHTING

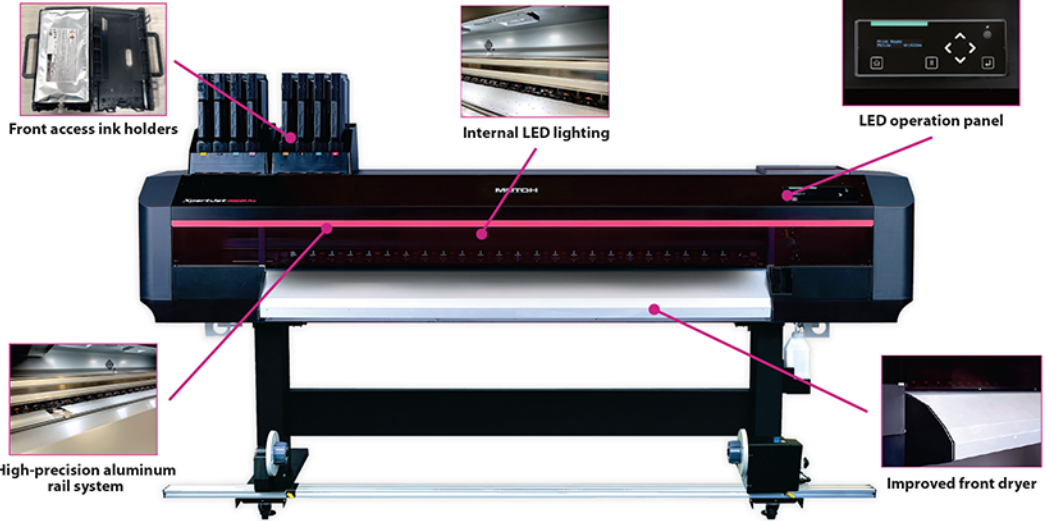

- **High-precision aluminum rail system** for high quality and stable printing.
- **Ease-of-use** with front access ink holders, side mounted LAN and power plugs, and LED operation panel.
- **New AccuFine HD printheads** provide faster speeds with exceptional quality.
- **Built-in sensors** for operator-driven automatic bi-directional and page feed alignments.
- **Improved front dryer system** for 20% faster ink dry times.
- **Updated media flanges and media feeding mechanism** allow for easy loading and page feed.
- **Internal LED lighting** for unobstructed print viewing and maintenance access.
- **Includes the MUTOH Status Monitor (MSM)** companion software for convenience and efficiency.

www.MUTOH.com | 1-800-99MUTOH



XPERTJET 1682SR PRO SPECIFICATIONS

Printing method	Drop-on-demand Micro Piezo Inkjet Technology
Printhead height	Four-level adjustment: 1.5mm, 2.0mm, 2.5mm, 4.0mm
Printhead	2 (staggered)
Max print resolution	1200x1200 dpi (1200/900/600/300 dpi print modes)
Media width	64 in
Media capacity	ø 5.9" dia / 2" & 3" cores / Roll media 66lbs or less
Max media thickness	Low1 0.3mm, Low2 0.8mm, Mid. 1.3mm, High 2.8mm
Max printable width	63.58 in
Max print speed	1,225 sqft/hr (300x600 dpi)
Take-up system	VJ16/19-TUP30 66lb take-up included (other options available)
RIP software	VerteLith™, bundled with FlexiDESIGNER MUTOH Edition 21

Ink	Type	MS41 Eco-Solvent ink
	Ink Set	4 color (CMYK) 8 color (CMYKLCmLkOr)
	Volume	1 L ink bags (300mL bag for Orange)
	No. of slots	8
Interface		Gigabit-Ethernet (1000BASE-T)
Power Requirements		AC 100-120V± 10%, 50/60Hz ± 1Hz
Printable Environment		Temperature: 68-89.6°F Humidity: 40-60%RH (non condensing) Rec. environment: Temperature: 71.6-86°F
Power Consumption		Main: Operation status 1100W or less Standby: 30W or less
Dimensions (WxDxH)		Printer including stand: 109.05" x 35.23" x 56.22" cover closed
Weight		Body: 310lb Stand: 70.54lb