

# 2x

## Grow your business with double the power

Get double the Abode RIP Engines, double the Printer Permissions and double the Job Editors with ONYX Thrive, the only truly scalable end-to-end workflow solution with network licensing.

## Scalable network for total flexibility

ONYX Thrive provides a network-based license for a long term solution to grow with your business. Users can easily add RIPs, printers, workflow modules and job editors to meet the demands of any print environment.

- Supports two full workstations out of the box
- Two Adobe RIP Engines with every printer add-on
- Submit jobs from anywhere with Thrive Production Manager
- Take complete control of production at the click of a button

With 100% Adobe technology throughout, ONYX Thrive enables users to print right the first time.

Example configurations:

### Classic

Job Editor



Job Editor  
4 RIPs  
4 Printers

Print Only

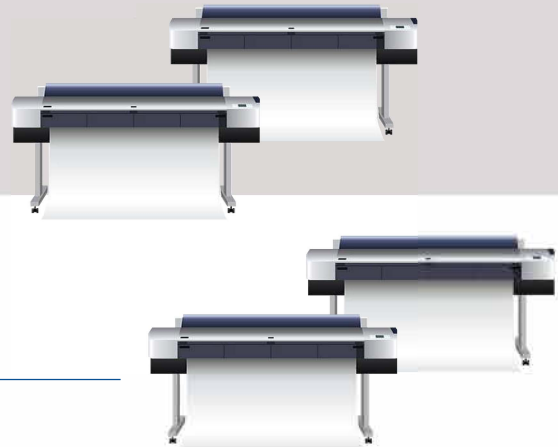

### Advanced

Job Editor

Job Editor



Job Editor  
8 RIPs  
3 Printers

Print Only

Print Only

Print Only

Print Only



Scalability	Performance	Predictability
<ul style="list-style-type: none"> <li>• Unlimited Thrive Production Manager for anywhere access to print production control</li> <li>• Add processing and printing capabilities independently</li> <li>• Access specific modules including ONYX Hub, ONYX Connect, ColorCheck and Accuboot for the most powerful workflow</li> <li>• Job ticketing to track job data</li> </ul>	<ul style="list-style-type: none"> <li>• QuickSets and unlimited hotfolders to speed up production and minimize errors from design to print</li> <li>• RIP and print on the fly with multiple files simultaneously</li> <li>• Printer pooling and automated workflows</li> <li>• Automated nesting, tiling and rotation with color managed previews including finishing marks</li> </ul>	<ul style="list-style-type: none"> <li>• Adobe technology throughout</li> <li>• Unique PowerChroma Black Generation and integrated ink savings with GCR+</li> <li>• Color Swatch Books color selection and matching including white and specialty ink support</li> <li>• ChromaBoost gamut mapping and extensive finishing and job editing tools</li> </ul>

## Reach new heights with ColorCheck

Exclusive for ONYX Thrive is ColorCheck: a new process control tool for users to prove color accuracy, consistency and conformance to standards including G7 and Fogra.



Easily match your customer brand-color needs consistently over time across all your devices and build repeat business.

*"ONYX Thrive has had a large impact on our business. With as much equipment as we have running at any one time, Thrive has been instrumental in keeping us fast, reliable and consistent."*

- Aaron Holland, DSR.

## Textile included in ONYX Thrive



With applications into decor, decal printing and soft-signage, ONYX Thrive allows users intuitive control to create patterns with PDF or any raster images and automated cutting workflows.

