

# HP Designjet 8000s Printer series



From small signs to large banners, this 64 in/1626 mm printer is the perfect tool for any print or sign shop. Experience a breakthrough price/performance combination with this low-solvent large-format device for a wide range of long-lasting applications.



## Print more, pay less

- **Heavy-duty HP printheads and HP supplies for maximum productivity**  
Experience high-speed printing with six heavy-duty Piezo printheads that come with 254 nozzles per printhead for a total of 1,524 nozzles. 500 ml, HP 780 ink cartridges are designed to meet your usage needs.
- **Produce striking signs with this in-the-box RIP: Onyx® SignEZ v2.0 for HP Designjet**  
Providing you with the essential tools to get started, this software RIP is easy to use and navigate, has basic color correction tools, basic nesting and tiling, and support for contour cutting.
- **Minimize your costs and get lasting output on uncoated media**  
Count on excellent quality output on a range of low cost, uncoated materials, such as adhesive vinyls, films, banner stocks, papers, and fabrics.
- **Enable long, unattended print runs for improved productivity with optional Take-Up Reel Kit**  
This optional accessory enables busy print and sign shop employees to be more productive by maximizing unattended printing with four winding modes: slack/face-in, slack/face-out, tight/face-in, and tight/face-out.

## Vivid colors with excellent durability

- **Wow your clients with vivid color output that shines brightly**  
Create signs, banners, and large graphics with such vivid color, they radiate success. Sophisticated HP "low-solvent"<sup>(1)</sup> ink formulations and printhead technology enable a higher concentration of colorants in the inks to produce a wider gamut of rich, saturated color. The result - more vivid color for high impact image quality.
- **HP low-solvent inks - excellent durability without lamination on low-cost, uncoated media**  
Designed with the HP 8000s Printer, HP low-solvent ink formulations produce durable prints that resist fading for three years without lamination and are scratch, smear, and crack resistant.<sup>(2)</sup>
- **Premium image quality - HP printing materials designed with HP low-solvent inks**  
With HP Premium Scrim Banner, HP Universal Scrim Banner, and HP Premium Backlit Film, get premium image quality and high opacity.

## A comprehensive HP solution

- **Purchase your large-format printer and the supplies you need from your one-stop shop: HP**  
Getting your business up and running couldn't be easier when you choose HP. Purchase the hardware and the supplies you need - including HP ink supplies and HP printing materials - from a single vendor.

- **At HP, we make it easy for you to grow your business with this comprehensive, scalable solution**

Not only does HP deliver a reliable, top-quality printer, we also provide the optional accessories you need as your business grows to produce multiple signage applications - including a Take-Up Reel Kit, High Speed Dryer, and Air Purifier System - easily and efficiently.

- **Avoid trial and error with customized media profiles**

The HP Designjet 8000s Printer series, its ink supplies, and HP printing materials are designed together. Customized media profiles optimize interaction between HP low-solvent inks, HP printing materials, and the Designjet printer to maximize system performance. Less trial and error makes your job easier and increases productivity.

## Safety and support-at HP, your needs come first

- **Have a clean, safe print environment with an integrated air purifier created for HP Designjets**

This printer-connected system uses a sealed, carbon-activated filter and high-powered fan to filter air at a rate consistent with the print speed and the number of volatile organic compounds released during the printing process.

- **HP guidelines help make HP low-solvent ink printing safe, productive, and easy**

Following HP's installation and use guidelines helps you achieve a reliable and productive low-solvent ink printing solution and helps you address environmental, health, and safety questions about printing with HP low-solvent inks.

- **Designed together for HP quality and reliability**

The HP Designjet printing system - printers, low-solvent inks, ink cartridges, printheads, and printing material - is engineered to work with precision and must meet strict HP quality standards. Reliable operation saves you time and improves your productivity.

- **HP offers the cleaning supplies and replacement ink cartridges needed to maintain your system**

HP training and guidelines help you implement environmentally responsible and safe practices for the purchase, installation, operation, handling, and maintenance of HP low-solvent printing supplies.

- **Experience peace of mind, knowing you're covered with HP's award-winning service and support**

HP's customer service and support backs every product with fast, knowledgeable online e-Support available 24/7 at [www.hp.com/support](http://www.hp.com/support), and easy-to-access phone support provided by HP trained agents. Plus, you can enhance your warranty protection with the purchase of affordable HP Care Pack Services.

<sup>(1)</sup> HP "low-solvent" inks are defined according to what is currently known in the industry as low-solvent inks.  
<sup>(2)</sup> Based on internal HP testing under specific test conditions; relative to key competitors.

# HP Designjet 8000s Printer series

1. Up to 64 in/1626 mm wide
2. 500 ml, HP 780 ink cartridges
3. Interactive front panel
4. USB 2.0 Hi-speed connectivity
5. 3 Integrated heaters
6. Easy media-loading
7. Exhaust attachment for efficient removal of Volatile Organic Compounds (VOC) included in the printer box
8. Printhead height adjustable to 2 different positions
9. Manual cutter
10. Container for cleaning kit

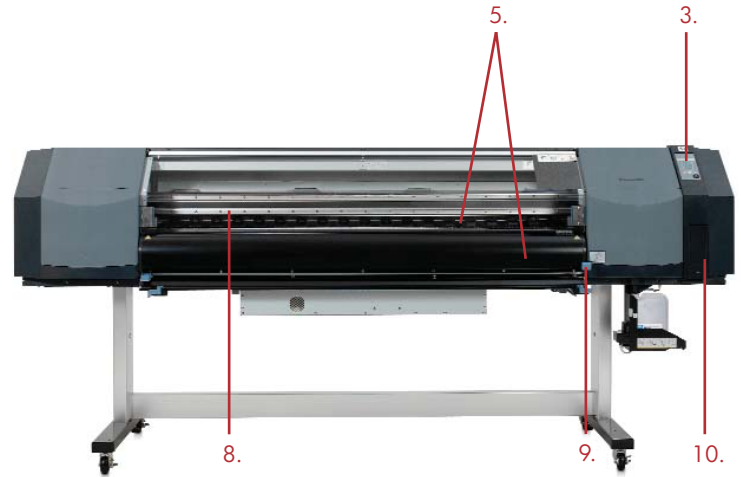
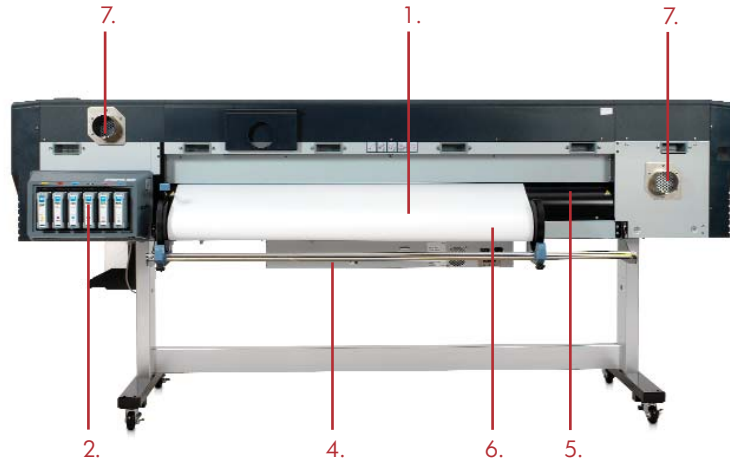

Manual cutter



Container for cleaning kit



Exhaust attachment & supplies detail

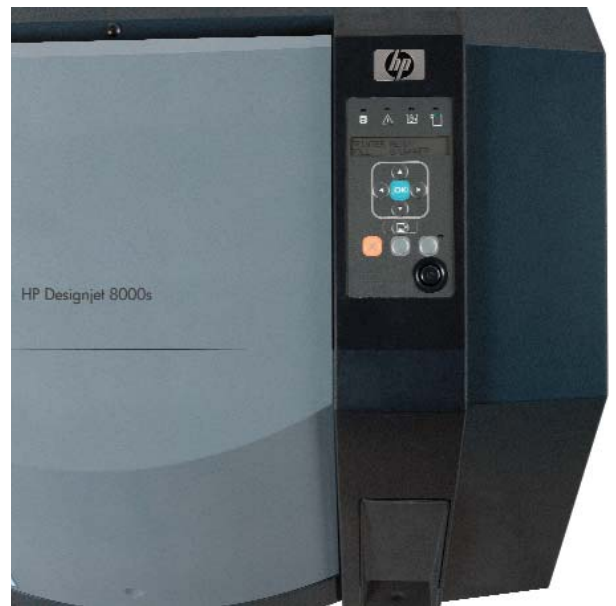

Interactive front panel



Edge guard & integrated heater



Easy media loading

## HP Designjet 8000s Printer series at a glance

### HP Designjet 8000sr Printer

#### In the box

HP Designjet 8000s Printer,  
Onyx® SignEZ v2.0 for HP Designjet\*

\* Onyx® SignEZ v2.0 for HP Designjet IS NOT available as a standalone accessory

#### Optional accessories

- HP Designjet 8000s Air Purifier System
- HP Designjet 8000s Take-Up Reel Kit
- HP Designjet High Speed Dryer
- Onyx® PosterShop® 6.5 for HP Designjet

### HP Designjet 8000sf Printer

#### In the box

HP Designjet 8000s Printer,  
HP Designjet 8000s Air Purifier System

#### Optional accessories

- HP Designjet 8000s Take-Up Reel Kit
- HP Designjet High Speed Dryer
- Onyx® PosterShop® 6.5 for HP Designjet

The HP Designjet 8000s Printer series, HP low-solvent ink cartridges, and printing material were all designed, engineered and tested together to ensure uncompromising reliability, image quality, durability, performance and ease of use. The total HP printing solution is composed of the following accessories:



HP Designjet 8000s Air Purifier System



HP Designjet High Speed Dryer



HP Designjet 8000s Take-Up Reel Kit



Onyx® PosterShop® 6.5 for HP Designjet

## HP Designjet Air Purifier System

Put your confidence in HP. Add this air purifier system (APS) - specially designed for HP low-solvent inks - to your HP Designjet printer for highly efficient air filtration. The APS includes the tubes that connect to the printer.

Count on HP for a clean, safe\* print environment

- **Highly effective carbon filter removes hazardous substances released from solvent inks**

The air purifier system developed for the HP Designjet 8000s Printer series uses carbon filters to extract from the air volatile organic compounds released during the printing process.

- **Return cleaned air to the working area or divert it outside**

This air purification system is equipped with a standard sealing device, and collected pollutants are led automatically through the filter.

Easily operate with front-panel display unit

- **Access air purification system data through a front-panel display unit**

Unlike some air purification systems, this system has a front-panel display unit that allows you to access certain data, such as run-on time to automatically stop purifier operation a certain amount of time.

- **Easily replace the filter through the front door on the system**

The front door of the air purification system opens safely and easily for quick filter replacement. A notification on the front-panel

\* When used appropriately, according to the product's guidelines.



Complete solution

## HP Designjet 8000s Take-up Reel Kit

- **Print long runs or on long printing materials**

Does your shop have more to print than it can keep up with? Extend its periods of continuous, unattended printing. This take-up reel re-rolls printed media, allowing for long print runs - for example, overnight - and printing on long printing materials.

- **Rely on heavy-duty media feed and take-up system**

This accessory turns and winds up onto a reel printed media. Print long runs, on long printing materials, and easily handle

completed prints. Sturdy reel supports four positions-slack/face-in, slack/faceout, tight/face-in, and tight/face-out.

- **Improve workplace efficiency**

With this media take-up reel, print and sign shop employees can make the most of their time and be more productive. Shops better meet client deadlines by maximizing unattended printing - even overnight - and efficiently collecting prints for finishing.



Take-Up Reel Kit



HP Designjet 8000s with Take-Up Reel kit

## Onyx® PosterShop® 6.5 for HP Designjet

Use this Onyx® PosterShop® RIP to print job after job of the best colors your printer can produce. Efficiently manage jobs and handle production with job preflight and printer queue tools.

### Print the colors your customers expect

- Make color changes - to precise spots or entire images - with intuitive color correction tools
- Have CMYK colors pop with PosterColor color rendering technology by Onyx®
- Match colors as closely as possible to the Pantone Color Library

### Print and customize jobs quickly and easily

- Modify jobs and see final layout on your screen before printing with easy-to-use preflight controls
- Print directly from your creative applications or from Hot Folders that specify job properties
- Add cut marks to your print jobs easier than ever with this RIP's contour cutting workflow

### Manage medias and calibrate your printer as needed

- Use the RIP's default media calibration tables, or add and calibrate your own printing materials

### Minimum PC operating system requirements for the Onyx® PosterShop® 6.5 for HP Designjet

Windows 2000 Server with latest SP, Windows 2000 Professional with latest SP, Windows XP Professional SP2, Intel Pentium III/AMD Athlon, 1.5 GHz or higher, 40 Gb hard drive, 1 GB RAM per CPU, 1280 x 768 16 bit colour display, DVD-ROM drive

## HP Designjet High Speed Dryer

Add this high-speed dryer to your HP Designjet 8000s Printer and accelerate drying time.

### Improve productivity - dryer reduces drying time

- **Dry prints as quickly as the automatic take-up reel\* can roll them up**

With the high-speed dryer and take-up reel,\* you can complete jobs at a rate of up to 165 ft<sup>2</sup>/hr (15.3 m<sup>2</sup>/hr). The integrated dryer and take-up reel enable unattended print runs.

### Easily operate high-speed dryer

- **Completely dry prints with user-adjustable heater and blower unit**  
Use variable controls on top of the dryer unit to set the heater temperature and to adjust the fan airflow.
- **Dryer's off timer allows unattended drying for up to 12 hours**

### Count on a dryer that was designed for safety

- **Built for high-volume, commercial print environments**



Detail on variable controls

# HP Designjet 8000s Printer series

## Technical specifications

<b>Print speed</b>	
Best	44 ft <sup>2</sup> /hr (4.08 m <sup>2</sup> /hr), color image on vinyl media
Normal	88 ft <sup>2</sup> /hr (8.17 m <sup>2</sup> /hr), color image in vinyl media
Fine Draft	110 ft <sup>2</sup> /hr (10.2 m <sup>2</sup> /hr), color image on vinyl media
Draft	165 ft <sup>2</sup> /hr (15.3 m <sup>2</sup> /hr), color image on vinyl media
<b>Print resolution maximum</b>	720 x 720 dpi
<b>Print margins</b>	
Normal	(Top x bottom x right x left): 0.2 x 0.2 x 0.2 x 0.2 in/5 x 5 x 5 mm
Using paper edge guard	(Top x bottom x right x left): 0.2 x 0.4 x 0.2 x 0.4 in/5 x 10 x 5 x 10 mm
<b>Memory</b>	257 MB
<b>Media</b>	
Handling	Sheetfeed, roll feed, optional take-up reel, manual cutter
Types	Paper, self-adhesive vinyl, banner scrim, films, fabrics
Thickness	0.0020-0.024 in/0.07 - 0.063 mm
Printhead height	0.826 to 0.102 in/2.1 to 2.6 mm
Maximum width	64 in/1626 mm
Maximum roll weight	52.9 lb/24 kg
<b>Printing</b>	
Technology	Piezo-electric inkjet heads
Print cartridge colors	Cyan, magenta, yellow, black, light cyan, light magenta
Ink types	HP low solvent pigmented inks
Ink drop	13 pl
Ink cartridge size	500 ml
Nozzles	254 nozzles per head x 6 colors
Maximum print length	15 m (RIP dependable)
Print accuracy	+/- 0.3 % or +/- 5 mm whichever is larger
<b>Interfaces (Standard)</b>	USB 2.0 Hi-speed
<b>Dimensions (w x d x h)</b>	
Printer	112 x 32.6 x 49.4 in/2846 x 830 x 1255 mm
Shipping	116.5 x 38.5 x 36.6 in/2960 x 980 x 930 mm
<b>Weight</b>	
Printer	478 lb/217 kg
Shipping	708 lb/321 kg
<b>What's in the box</b>	
HP Designjet 8000sr Printer	HP Designjet 8000sr Printer, USB cable, coated paper, cleaning kit, ink cartridges (6), ink box cover, printhead set (6), waste-ink bottle holder, waste ink bottle (2), exhaust attachment kit, stand assembly including screws and open ended spanner, pipe for media support, media support holder (2), media support stay (2), screws and screwdriver for assembly, power cord, CD (containing user guide, legal information and maintenance guide), hard copy users guide & maintenance guide, 3 inch paper roll flanges (2), paper roll flange spacer (2), Onyx® SignEZ v 2.0
HP Designjet 8000sf Printer	HP Designjet 8000sf Printer with HP Designjet 8000s Air Purifier System included, USB cable, coated paper, cleaning kit, ink cartridges (6), ink box cover, printhead set (6), waste-ink bottle holder, waste ink bottle (2), exhaust attachment kit, stand assembly including screws and open ended spanner, pipe for media support, media support holder (2), media support stay (2), screws and screwdriver for assembly, power cord, CD (containing user guide, legal information and maintenance guide), hard copy users guide & maintenance guide, 3 inch paper roll flanges (2), paper roll flange spacer (2), Onyx® SignEZ v 2.0

Energy Star® Energy Star logo® are US registered marks of the United States Environmental Protection Agency. Microsoft and Windows are U.S. registered trademarks of Microsoft Corporation. Adobe® and Adobe®PostScript® 3™ are trademarks of Adobe Systems Incorporated. AutoCAD is a U.S. trademark of Autodesk, Inc. © 2004 Hewlett-Packard Development Company, L.P. The information contained herein is subject to change without notice. The only warranties for HP products and services are set forth in the express warranty statements accompanying such products and services. Nothing herein should be construed as constituting an additional warranty. HP shall not be liable for technical or editorial errors or omissions contained herein.

## Accessories - technical specifications

<b>HP Designjet 8000s Air Purifier System</b>	
<b>What's in the box</b>	HP Designjet 8000s Air Purifying unit with 1 filter element inside, APS printer connection set, User's Guide, Power cord in compliance with regional power connections
<b>Product weight</b>	132 lb/60 kg plus tube
<b>Package weight</b>	176 lb/80 kg
<b>Product dimensions</b>	14.3x31.5x31.3in/365x801x 797mm
<b>Package dimensions</b>	22.4x35.4x44.8in/570x900x1140mm
<b>Power consumption</b>	1100 watts
<b>Fan power</b>	6356 ft <sup>3</sup> /hr (180 m <sup>3</sup> /hr)
<b>HP Designjet 8000s Take-Up Reel Kit</b>	
<b>What's in the box</b>	Take-up Reel Unit, Take-up Reel Sub-unit, Plate Assembly Right, Plate Assembly Left, IR-LED Assembly, Tension Roller Assembly, Attachment Flange, Paper Tube, Clamp Guide x 2, Washer x 3, M5x10 Screws x 9, Cable Assembly, Installation Guide
<b>Product weight</b>	55 lb/25 kg
<b>Package weight</b>	63.9 lb/29 kg
<b>Product Dimensions</b>	78.7 x 19.7 x 27.6 in/2000 x 500 x 700 mm
<b>Package dimensions</b>	2000 x 472 x 430 mm
<b>Maximum media roll weight</b>	52.9 lb/24 kg
<b>HP Designjet High Speed Dryer</b>	
<b>What's in the box</b>	Dryer unit, Support stay, Foot with castor X 2, Stand X 2, M5 x 12L hexagon socket head bolt X 16, Hexagon bar wrench, User's guide, Power cord in compliance with regional power connections
<b>Product weight</b>	88 lb/40 kg
<b>Package weight</b>	132 lb/60 kg
<b>Product dimensions</b>	2416 x 612 x 903 mm
<b>Package dimensions</b>	99.6 x 27 x 13 in/2530 x 690 x 335 mm

## Ordering information

<b>Product</b>	Q6670A HP Designjet 8000sr Printer Q6671A HP Designjet 8000sf Printer
<b>Accessories</b>	Q6669A Onyx® PosterShop® 6.5 for HP Designjet Q6673A (220V) HP Designjet 8000s Air Purifier System (Included in the box with HP Designjet 8000sf Printer) Q6673B (110V) HP Designjet 8000s Air Purifier System (Included in the box with HP Designjet 8000sr Printer) Q6681A HP Designjet 8000s Take-up reel Kit Q6667A HP Designjet High Speed Dryer Q6682A HP Designjet 8000s Cutter Blade Kit Q6679A HP Designjet 8000s/9000s APS filter
<b>Service &amp; Support care packs</b>	UE232E Installation and Start-up Designjet UE157A 3 year Next business day UE157E 3 year Next business day UE158E 4 year Next business day UE159E 5 year Next business day UE166PA 1 year Post warranty, Next business Day UE166PE 1 year Post warranty, Next business Day
<b>Ink supplies</b>	
<b>Cartridges</b>	CB285A HP 780 Black Ink Cartridge, 500 ml CB286A HP 780 Cyan Ink Cartridge, 500 ml CB287A HP 780 Magenta Ink Cartridge, 500 ml CB288A HP 780 Yellow Ink Cartridge, 500 ml CB289A HP 780 Light Cyan Ink Cartridge, 500 ml CB290A HP 780 Light Magenta Ink Cartridge, 500 ml
<b>Waste Ink Bottle</b>	CB291A HP 780 Waste Ink Bottle
<b>Cleaning Kits</b>	CB301A HP 780 Wiper Cleaning Kit CB302A HP 780 Cap Cleaning Kit CB303A HP 780 Ink System Cleaning Kit CB308A HP 780 Ink System Storage Kit
<b>Media supplies</b>	Q8678A HP Premium Scrim Banner 36 in x 164 ft/914 mm x 50 m Q8679A HP Premium Scrim Banner 54 in x 100 ft/ 1372 mm x 30.5 m Q8680A HP Universal Scrim Banner 36 in x 164 ft/914 mm x 50 m Q8681A HP Universal Scrim Banner 54 in x 100 ft/1372 x 30.5 m Q8682A HP Premium Self adhesive Vinyl- 54 in x 150 ft/ 1372 mm x 45.7 m Q8683A HP Premium Self adhesive Vinyl- 60 in x 150 ft/ 1542 mm x 45.7 m Q8684A HP Premium Backlit Film 36 in x 66 ft/ 914 mm x 20.1 m Q8685A HP Premium Backlit Film 54 in x 66 ft/ 1372 mm x 20.1m Q8686A HP Universal Photo-realistic Paper- 36 in x 150 ft/ 914 mm x 45.7 m Q8687A HP Universal Photo-realistic Paper- 54 in x 150 ft/1372 x 45.7 m

For more information, visit our website at  
[www.hp.com/go/designjet8000s](http://www.hp.com/go/designjet8000s)

